



Blastclean Systems Pvt. Ltd.
(Created to Prevent Corrosion)

CORROSION PREVENTION SOLUTIONS AND SERVICES

- ★ AUTOMATIC SHOT BLASTING EQUIPMENTS
- ★ SEMI-AUTOMATIC SHOT BLASTING EQUIPMENTS
- ★ AUTOMATIC SHOT BLASTING & PAINTING LINES
- ★ SEMI-AUTOMATIC SHOT BLASTING & PAINTING LINES
- ★ PAINTING BOOTHS
- ★ DUST COLLECTORS
- ★ BLAST CABINETS
- ★ FUME EXTRACTION SYSTEMS
- ★ MATERIAL HANDLING SYSTEMS
- ★ SERVICES AND CONTRACT

www.blastcleansystems.com

Welcome to Blastclean Systems Pvt. Ltd

A company created to prevent corrosion, by a small group of highly experienced professionals in the field of surface preparation and coatings. In today's competitive and ever demanding market, the formula for success includes effective utilisation of latest technology for best results at lowest cost and by providing expert and timely services. At Blastclean Systems we believe in this and try to give one point solutions to all your needs of surface preparation and painting which includes equipment design to complete operations & maintenance. Blastclean Systems have its own well experienced team of engineers who can suggest what type of equipment and process can give best results with most cost effective methods.

The blasting technology is a process of hurling abrasives at high velocity at the job to clean the job from all impurities and to create an anchor profile. This looks pretty simple but in the world of shot blasting equipments, simple does not mean maintenance free considering shot blasting equipments are self-destructive equipments. This is where the team of Blastclean Systems will play a vital role in installing, operating and maintaining the machines with minimal running cost.

Quality Standards

"Blastclean's" dedication to providing the best products and services to our customers is reflected in our quality standards that not only meets but also are well above industry standards. "Blastclean" is an ISO 9001:2015 Certified company, always recognized for its quality and performance, We adhere to the strict standards of our well-developed Quality Standards and Program. To ensure Blastclean's design remain current and up to date, we work on the policy of continuous improvement and conduct regular external & internal audits and training programs. It's our aim to ensure all personnel, processes and programs are performing to their highest potential at all times. Our aim is to provide each one of our client with products of Best quality at lowest price and on time delivery.

Our Strength

- Our team is our strength, who have Rich hands on experience in the field of Surface preparation, equipment design, manufacturing, installation, operation, maintenance, working in projects sites of blasting & Painting.
- Our teams are spread all over India, which helps in reaching out and attending customer's calls faster.
- In-house manufacturing facility with last equipment's and personalised attention in manufacturing.
- Strong inspection, installation and service teams.
- Strong design and drawing team.
- Always Stock of critical spares.
- Availability of highly qualified personnel's with certification such as NACE.





Blastclean Systems Pvt. Ltd.
(Created to Prevent Corrosion)



AUTOMATIC SHOT BLASTING EQUIPMENTS

Automatic shot blasting is high productive, best and consistent quality shot blasting process. This is an airless type of surface preparation method which is done using high rpm Turbines and without use of any compressed air. Automatic shot blasting machines are designed with various types of conveyer systems. Rollers conveyor, monorail/ Hanger conveyor, Diablo type rollers, Tire type rollers, trolley type conveyor, table type ,belt conveyor, mesh conveyors etc.

AUTO-BLASTING LINE FOR PLATES & SMALL SECTIONS

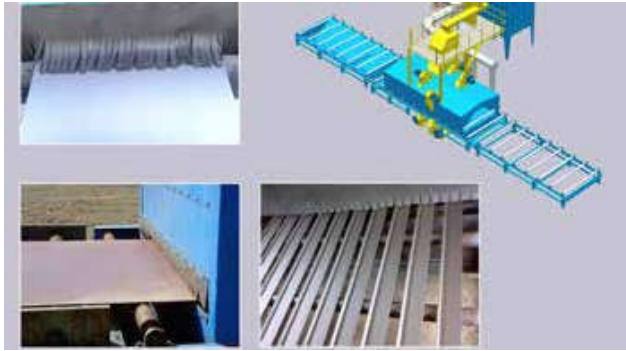

Automatic shot blasting machine with roller conveyors for Plates, flats, bulb bars, rolled angels, channels and other flat products. This type of machine is widely used in ship building industry, Storage tank projects etc. where large amount of plates are used. These machines have built in Brush off and blow off system for automatic cleaning of abrasives from the job. Machines are available from 1 meter to 4 meter conveyor width.

AUTO-BLASTING LINE FOR STRUCTURAL STEEL

Most commonly used machine in Fabrication industry, power projects, petrochemical construction projects etc. All types of structural steel products can be shot blasted with this machine. Machines are available with opening size from 1meter x 1 meter to 3 meter x 2 meter opening size.



AUTO-BLASTING FOR FABRICATED STRUCTURE & PANELS



These type of machines are widely used in automobile & steel fabrication industry. Fabricated structure, Chassis of vehicles, panels of tippers and trailers etc. are shot blasted on SKD form on these machines. Turbines are designed and located in such way that the job is shot blasted from all angles. Machine are available of sizes ranging from 2.5 meter x 0.5 meter opening to 3.5 meter x 2 meter opening.

AUTO-BLASTING WITH MONORAIL MULTI-PRODUCT

Used for various types of jobs in Automobile, casting & foundry, fabrication industry for pipe fitting in piping projects etc. Multiple jobs are loaded on the hangers at a time for shot blasting. These are high productive machine and also used for batch type production. Machines are available in various sizes and variety of jobs.



AUTO-BLASTING FOR PIPES



Diablo type rollers and tire type conveyor are used to convey Pipe for automatic shot blasting process. Machine can be designed for pipe ranging from 1/2" to 60" dia and normally supplied with Feeding, buffer stock, loading & unloading systems. Very commonly used in pipe coating industry, pipe lines projects in petroleum, power, oil & gas, petrochemicals industries. Machine can be designed of the size & design of fright container which can be used for cross country pipe line projects.

INTERNAL PIPE BLASTING

Internal pipe / Mould cleaning machines are available from 4" dia pipe to 3 mtrs dia pipes. Machines are designed as per customer requirement with suitable handling system. Automatic / manual lance systems are used with pressure blasting technology for internal blasting.



AUTO-BLASTING WITH TURN TABLE

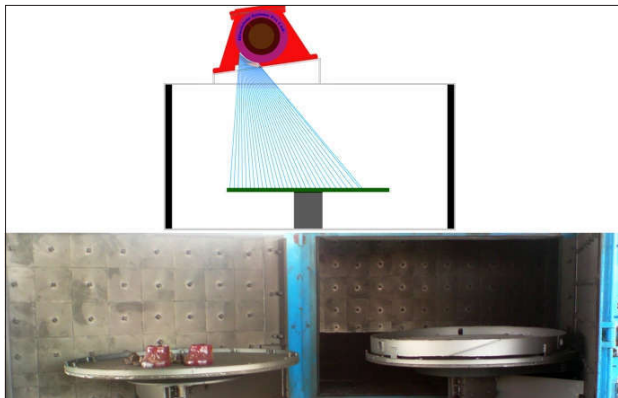

Swing table is the commonly known name for table type machine. Used by small and medium industry for various size of components. Machines are available with Table size from 1 meter diameter to 2.5 meter diameter.

AUTO-BLASTING WITH BELT / MESH CONVEYOR

Perforated wear resistance belt and mesh type conveyor is used for small components in mass production lines. Commonly used in pavement tiles, utensils manufacturing, small component manufacturing industry. It can be designed from 500mm wide to 1.2 meter wide conveyor system.



AUTO-BLASTING SPINNER HANGER

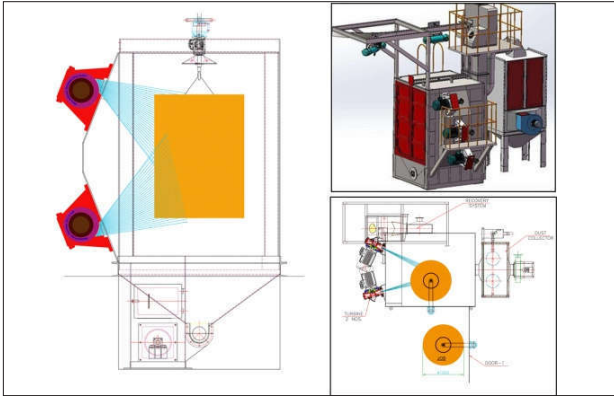

This is batch type automatic shot blasting machine, on which bunch of jobs can be loaded. Loading of jobs can be on the hook provided on the door, Y track system or hoist provided on the machine. Machine can be designed in various sizes and capacity as per the requirement of customer.

AUTO-BLASTING TUMBLE BLAST

This batch type machine for small components. Jobs are continuously tumbled by the Mill conveyor which would be running in the opposite direction that is (Climbing) and which, while carrying the pieces would tumble the same, hence bringing each individual part completely under the blast stream. This would enable the complete cleaning of any individual part.



AUTOMATIC SHOT BLASTING & PAINTING LINES

These equipments are one point solution for complete surface preparation & painting job. These machines are integrated with handling, pre-cleaning, pretreatment, drying, shot blasting, painting & drying systems. Job once loaded on to the conveyor will come out after completing all process of corrosion prevention. These lines are designed with roller conveyor as well as monorail conveyor system. Options can be provided for automatic or manual spray painting and can be designed as per the size of job and requirement of end user. Equipment can be supplied with various types of conveying system.





SEMI-AUTOMATIC SHOT BLASTING EQUIPMENTS

Semi-automatic shot blasting equipments are booth type machines where in the operator can walk in to the booth and carry out the shot blasting as per requirement. Advantage of this system is that it can accommodate variety of jobs. This is batch type machine where the job can be conveyed in to the booth by trolley, crane, monorail or by hand. In this machine the shot blasting is done manually but recovery, recycling & dust collection etc are all automatic processes. Machine can also be designed with complete auto recovery as well as semi-automatic recovery system. and capacity as per the requirement of customer.

BLAST BOOTH WITH AUTO-RECOVERY SYSTEM

Blast booth are designed with modular construction with steel panels, entry exit doors, man door, emergency doors, rubber lining, Lighting, etc. Booth will have full floor recovery system. i.e. all abrasives used for blasting will be recovered, conveyed, cleaned and recycled by automatic abrasive recovery system. Dust collectors and ducting is provided for extraction of the dust generated during blasting, filter the air and discharge clean air to atmosphere. Pressure blasters with Automatic operator control are supplied with the booth for blasting operation.

Booth can be designed as per customer requirement ranging from 3 mtr x 3 mtrs x 3 mtrs to 50 mtr x 10 mtrs x 10 mtrs and more.

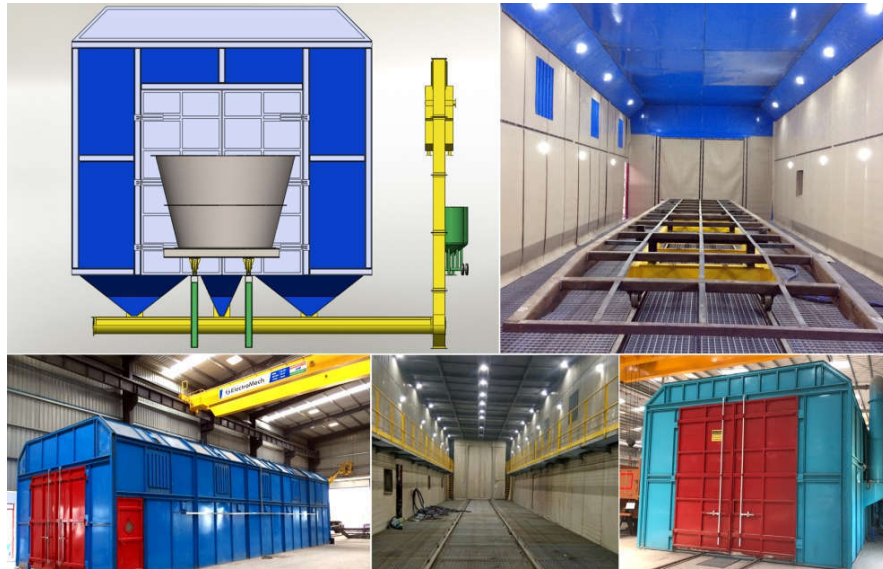

BLAST BOOTH WITH SEMI AUTO-RECOVERY SYSTEM

Booth Enclosure will be Modular as per above mentioned details. Recovery system will not be fully automatic. Collection hopper, Cross screw conveyor or H type screw/ belt conveyors are provided.



BLAST BOOTH WITH SUCTION RECOVERY SYSTEM

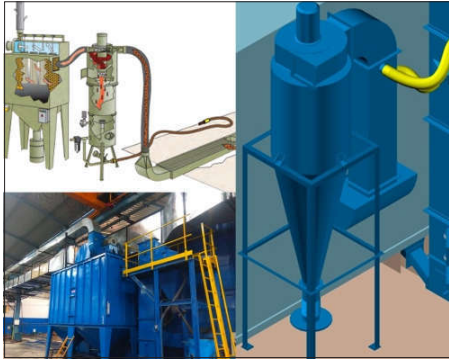

Booth Enclosure will be Modular as per above mentioned details. Recovery system will be trough suction recovery system. This method is used recover light weight abrasives like Glass bead, Al-oxide.

PORTABLE PRESSURE BLASTERS / BLAST POTS

These are most common and widely used blasting equipment in blasting industry. Mostly used on project sites for open air blasting & in blast rooms. Compressed air is used for operation of this equipment. Equipments can be supplied with manual operation as well and auto automatic control system. Sizes can be from 50 ltrs, 200 ltrs, 300 ltrs & 500 ltrs.

Double chamber pressure blasters are also available which are used for continues blasting operation and are used mostly on automatic pneumatic blasting machines.



SEMI-AUTOMATIC SHOT BLASTING & PAINTING LINES

These equipments are one point solution for complete surface preparation, painting & drying. which consists of handling, pre-cleaning, pre-treatment, drying, shot blasting, painting & drying stations. Once the job is loaded on the conveying system it will come out after completing all process of surface preparation & coating. These lines are designed with trolley system, roller conveyor, chain conveyor and monorail conveyor system etc. These equipments can be designed with full automatic recovery as well as semi-automatic recovery. Paint booth which is in line with the shot blasting can be dry type or water wash type as per the requirement.

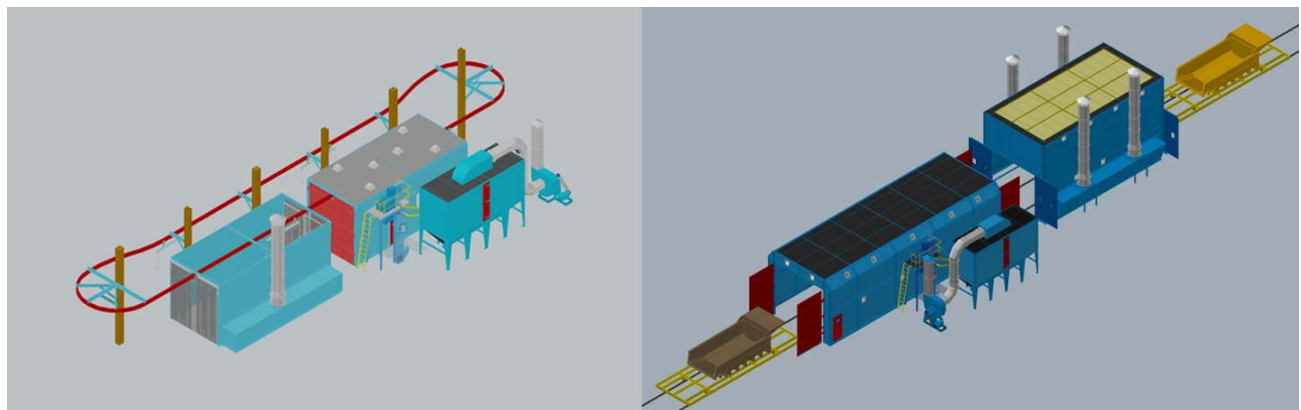

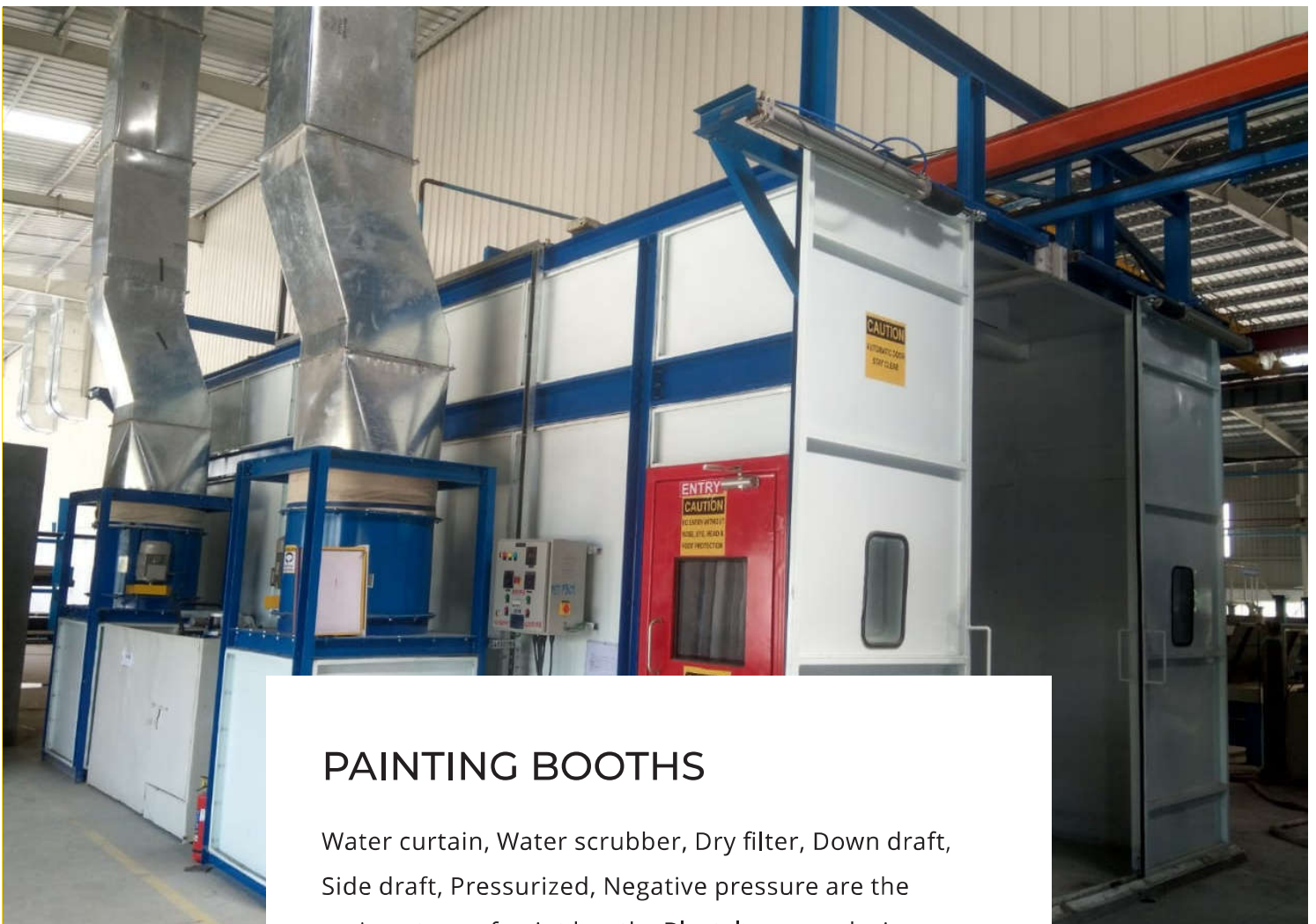

PAINTING BOOTHS

Water curtain, Water scrubber, Dry filter, Down draft, Side draft, Pressurized, Negative pressure are the various type of paint booths Blastclean can design, manufacture and supply of size as required by customer. Paint booth can be supplied with material handling system like trolley, roller conveyor, slat conveyor, monorail etc. Booths can be designed and supplied from size 2 mtr x 2 mtr to 50 mtrs x 10 mtrs x 10 mtrs.



DRY FILTER PAINT BOOTHS

Dry filter paint booths are environment friendly booths. Booth are designed with Down draft, Side draft & Semi down draft type. The airflow is designed with air flow from top of the booth towards bottom sides and to direct paint over spray over the filters. This will give maximum comfort to the operator and will maintain continuous fresh air movement in the booth. Venture type disposable card board filter are used for filtration system.



WATER CURTAIN PAINT BOOTH



Wet type paint booths supplied with water curtain system, water scrubber system and with full water floor system.

Booth are designed with Down draft, Side draft type. The airflow is designed with air flow from top of the booth towards bottom sides and to direct paint over spray over the water curtain . This will give maximum comfort to the operator and will maintain continuous fresh air movement in the booth.

PAINTING AND DRYING LINE

These equipments are one point solution for painting & drying. These finishing lines are integrated with handling, pre-cleaning, pre-treatment, painting & drying systems. Job once loaded on to the conveyor will come out after completing all process. These lines are designed with roller conveyor, trolley as well as monorail conveyor system. Options can be provided for automatic spray painting which can be designed as per the size of job and requirement of end user.





Blastclean Systems Pvt. Ltd.
Pune, India



DUST COLLECTORS

Dust collectors are one of the main parts of shot blasting machines. These can be supplied with Dry fabric type filters, cartridge type with reverse puls jet cleaning & cyclone type. Dust collectors are designed as per the size and process requirement of shot blasting equipment.





CARTRIDGE FILTERS WITH PULSE JET CLEANING

Reverse pulse jet cartridge dust collectors with most efficient dust collectors are used mostly on Automatic machines where continuous operations are needed. Cartridges are housed in MS chamber. Compressed air is used for clearing of filters. Sequential times and automatic valves are used for release of air as per design requirement. These are available from 1000 CMPH to 50,000 CMPH capacity.



DRY FABRIC BAG HOUSE DUST COLLECTOR



Dry Fabric bag house dust collector is a batch of fabric bag filters housed in a closed MS enclosure. Dust laden air is passed through these filters where the dust is arrested and fresh air is exhausted to the atmosphere. These dust collectors have good filtration capacity. Cleaning of the filters is done by shaking mechanism which is a automatic operation after each cycle time of operations. These type of dust collectors are widely used on Semi automatic shot blasting machines, food, color processing industry, stone crushers, etc. These are available from 1000 CMPH to 40,000 CMPH capacity.

CYCLONE DUST COLLECTORS

Cyclone dust collectors are used where heavy dust suction and separation is needed. Filtration efficiency is lowered when compared to Pulse jet and fabric bag dust collectors. Most used on blast rooms where steel media is not used and in other industries where heavy dust is generated. These are available from 3000 CMPH to 10,000 CMPH capacity.

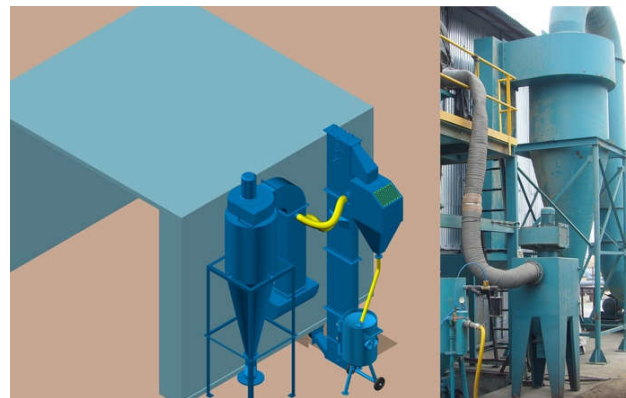

PORTABLE DUST COLLECTOR

Mounted on Wheels / skid can be taken from place to place. Can be used for abrasive cleaning and separation also. Can be designed and supplied as per customer / process requirement.



BLAST CABINETS

There are two types of blast cabinets available. One works high air volume, which is called pressure cabinet and other works of low air volume which is called suction cabinet. These are small equipments used for small components.

PRESSURE BLAST CABINETS



Pressure blast cabinets are for small components blasting. It's a portable equipment with in built pressure blaster, nozzle and with dust collector. Can be supplied with turn table, trolley for job handling.

SUCTION BLAST CABINETS



Suction cabinets are for very small jobs and for laboratory purpose. Cabinet is provided with hand gun for small area blasting.

FUME EXTRACTION SYSTEMS

Fume extraction systems are supplied to various industries some of them are rubber industry, tobacco processing, colour & power industry, big paint shops where paint booth is not possible to install. These are tailor made equipment and can be designed based on the requirement.



MATERIAL HANDLING SYSTEMS

Roller conveyor, Salt conveyor, chain conveyor, cross transfer stations, trolley systems, monorails etc. are designed, manufactured, supplied and installed as per customer requirement.



MANUFACTURING FACILITY

At Blastclean Systems Pvt. Ltd., we specialize in the manufacture of precision equipments and general fabrication of sheet metal and rolled sections using the latest technologies in order to provide our clients with faster and more cost-effective services while maintaining the highest quality standards.

Following is a small list of reasons why you should do business with us:

- ISO 9001:2015 CERTIFIED Company.
- "Blastclean" itself is an equipment manufacturer so the quality of product is assured.
- In-house Design, Engineering and auto-cad drafting team.
- Newly built factory with latest VFD driven EOT crane facility.
- Latest Manufacturing Technology, new generation CNC equipment's for profile cutting, bending & drilling.
- All processes under one roof including cutting, bending, drilling, fabrication, Painting etc.
- Custom design - Prototype to Production
- Backed by a committed work force of qualified Engineers, and high skilled employees.
- Specialized in panels, enclosures, booths, conveyor lines, structural fabrication.
- Easy access to both Mumbai & Pune by express way.

EQUIPMENT & CAPABILITY

Gantry type CNC profile cutting equipment with Hypertherm USA make cutting source having bed size of 1500mm Wide X 6100mm Long, cutting upto 25mm thickness plates, CNC Press brake 4 axis, 160MT with 3100mm bending capability, Double guarder EOT Crane with 8 mtrs Height with travel on full factory area. Loading unloading is directly done from truck/ trailer with this EOT crane and may other latest machineries required for fabrication.

SERVICES & CONTRACTING

1. Engineering & Construction projects
2. Operation & Maintenance contracts
3. Annual Rate contracts for shot blasting & painting
4. Annual Maintenance contracts

OUR SERVICES

Blastclean Protect Engineering & Consultants was commenced operations with a team of 22 employees. Today we are a team of more than 400 working with more than 20 esteemed clients like L & T, Alstom, GE, TATA, KVUL, Utkal to name the few, at different parts of India. It is our experience and dedication that our clients have come to know and expect of us to render our services. We have our senior staff with NACE certified coating Inspectors certification and provide NACE certified Coating Inspection Services and consultancy services.

BCP's objective is to excel in all aspects of the Corrosion Control industry including, high quality workmanship, latest technology and zero harm regarding the health and safety of all employees, clients, contractors, suppliers and the community as well as the environment in which we work. We pride ourselves in achieving superior customer service through reliable services within time frames and with cost effective methods to compete in ever demanding market.

Within a short period in business, we have established excellent relationships with our client's, suppliers, inspection authorities as well as OEM's.



Blastclean Systems Pvt. Ltd.
(Created to Prevent Corrosion)

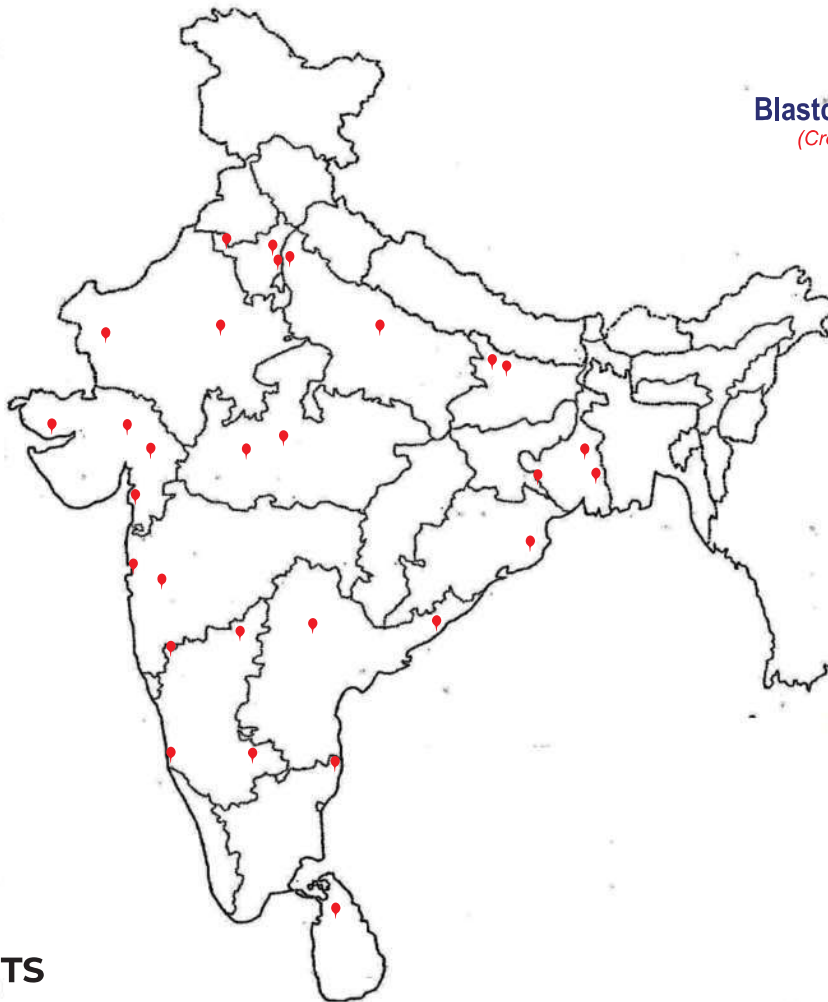

OUR CLIENTS



Contact

Corporate Office :

609, Swastik Disa Corporate Park,
Opp. Shreyas Cinema, L.B.S. Marg,
Ghatkopar (W), Mumbai - 400 086.
Maharashtra, India.

Tele no. : +91-22-25000211/ 0212

E mail : info@blastcleansystems.com

Reg. Office :

201, A-Wing, Shiv Sagar,
Bldg. No. 70, Tilaknagar,
Chembur, Mumbai - 400 089.

Tele no. : +91-22-2528 4555

Web Site : www.blastcleansystems.com

Factory :

Plot No. 25, Gat No. 185,
KIDC, Near Fiber Foils,
Dheku Village, Khopali,
Raighad District,
Maharashtra - 410 203.